

- 1 - POWER RELAY (30amp SPST contact)
- 2 - SPADE LUGS / WIRES for relay contacts
- 3 - LINE TRANSFORMER (120 or 230VAC)
- 4 - SPADE LUGS / WIRES for line voltage trafo.
- 5 - BOARD SPACERS
- 6 - PANEL MOUNTING STUD (#6-32) FOR FLUSH FACE
- 7 - BOARD SANDWICH MOUNTING SCREWS (#4-40)
- 8 - LED DISPLAY (3 digits) 3x 0.56" OR 3x 0.36"
- 9 - PUSH BUTTONS
- 10 - FLUSH FACE PLATE
- 11 - CONTROLLER BOARDS
- 12 - TRAF0/RELAY BOARD
- 13 - BRACKET MOUNT SET SCREW FOR SEMI-FLUSH FACE
- 14 - PANEL MOUNTING NUT FOR FLUSH FACE
- 15 - SEMI-FLUSH FACE PLATE
- 16 - WALL MOUNTSCREW FOR SEMI-FLUSH FACE

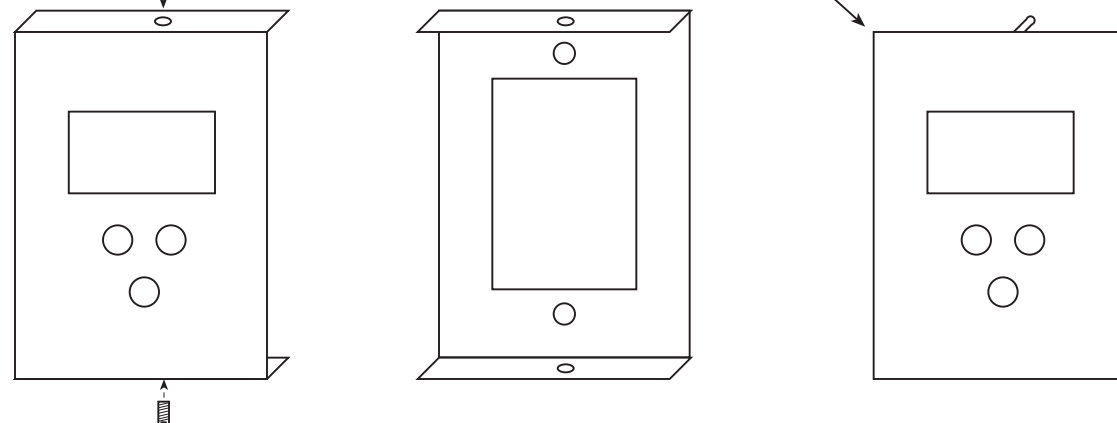

Tol: +/- 0.005"

| | | |
|--|---------------------------|------------|
| <i>KERA Technology</i> | | |
| Title | | |
| SDT(H,M)-3PB-HP HIGH POWER PLATFORM ASSEMBLY REFERENCE DRAWING (ASR) | | |
| Size | Number | Rev |
| B | SDHT3PBHP1R1-ASR | 1 |
| Date 19/06/05 | Drawn By T. Sarata | |
| File SDHT3PBHP1R1ASR | Sheet 1 of 1 | |