

# DSD-2 DIFFERENTIAL THERMOSTAT APPLICATION IN SOLAR HEATING SYSTEMS

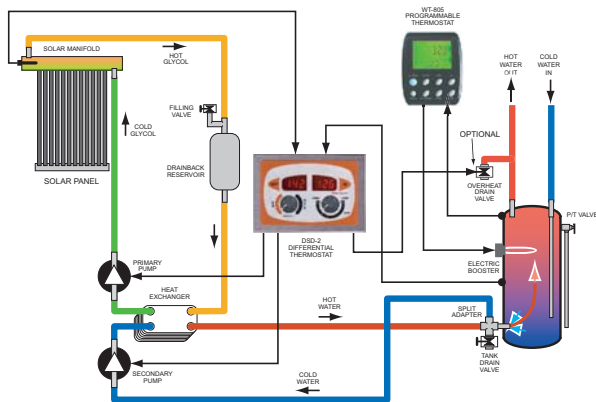

SPLIT DRAINBACK SYSTEM USING EXTERNAL HEAT EXCHANGER AND ONE STANDARD TANK

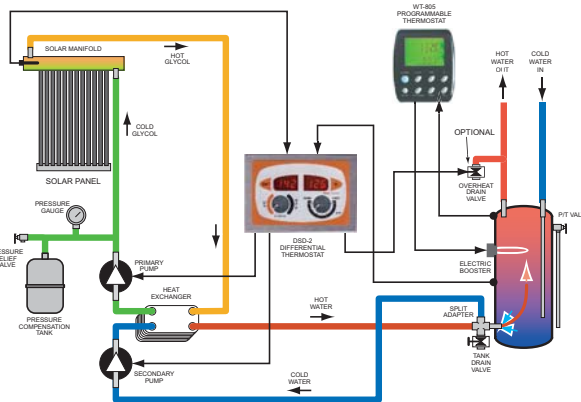

SPLIT PRESSURIZED SYSTEM USING EXTERNAL HEAT EXCHANGER AND ONE STANDARD TANK

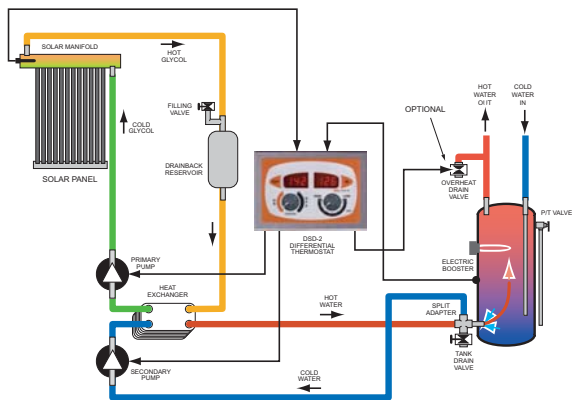

SIMPLE SPLIT DRAINBACK SYSTEM USING EXTERNAL HEAT EXCHANGER AND ONE STANDARD TANK

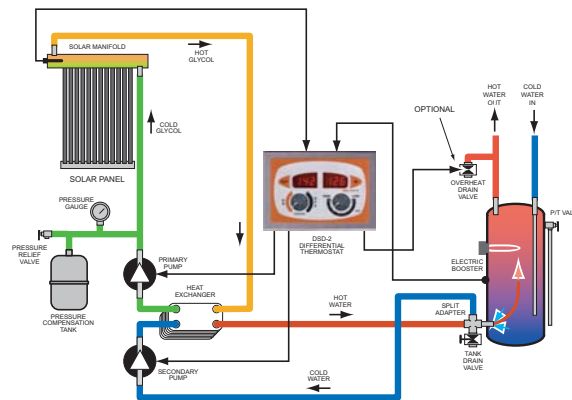

SIMPLE SPLIT PRESSURIZED SYSTEM USING EXTERNAL HEAT EXCHANGER AND ONE STANDARD TANK

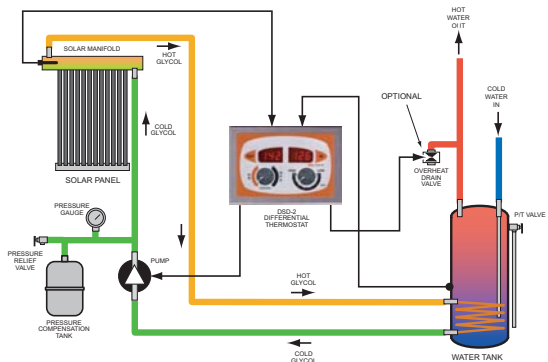

SIMPLE SPLIT PRESSURIZED SYSTEM USING ONE TANK WITH INTERNAL HEAT EXCHANGER

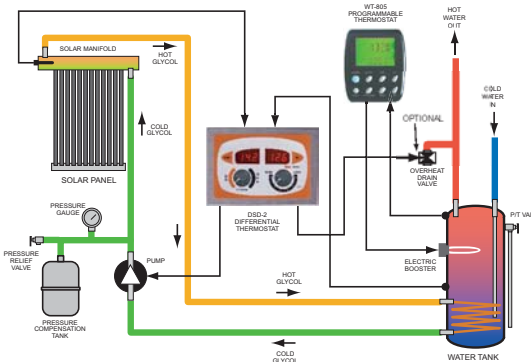

SPLIT PRESSURIZED SYSTEM USING ONE TANK WITH INTERNAL HEAT EXCHANGER

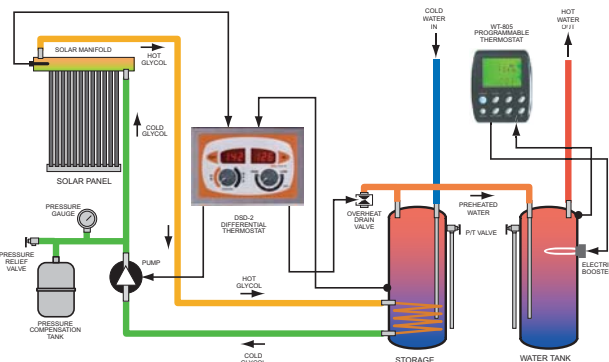

SPLIT PRESSURIZED SYSTEM USING ONE STORAGE TANK WITH INTERNAL HEAT EXCHANGER AND A SERVICE TANK WITH ELECTRIC BOOSTER

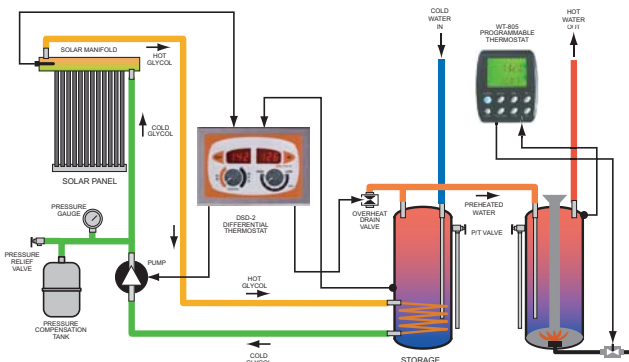

SPLIT PRESSURIZED SYSTEM USING ONE STORAGE TANK WITH INTERNAL HEAT EXCHANGER AND A SERVICE TANK WITH GAS BOOSTER